

Micropac Bagmatic  
**Micropac Bagmatic**

**HORIZONTAL WRAPPER**

Horizontal packaging machine with quick change over size, specially designed for small production batches: by setting bag length data via microprocessor keyboard the machine can run immediately without any other intervention of the operator.



**Product range:**

Bag range:

min. 75 mm / max. no limit

Bag length adjustment:

25 mm by 25 mm and multiple

Range of output:

up to 50 bags per minute



## Features and performances

- D.c. motor driven by PLC
- Reeholder suitable for 400 mm (15,7") max. width reel
- Forming tunnel adjustable by handwheel
- Product feeding belt 2000 mm (78,7") long
- Longitudinal sealing by wheels and tefloned belts
- Cross sealing and cutting by long dwell jaws assembly that accompanies the bag during sealing operation
- Cross sealing jaws 200 mm (7,9") driven by pneumatic cylinders
- Longitudinal and transversal sealing assemblies adjustable in height
- FESTO pneumatic parts
- CE rules
- Film width 400/500 mm
- Weight 600 kg

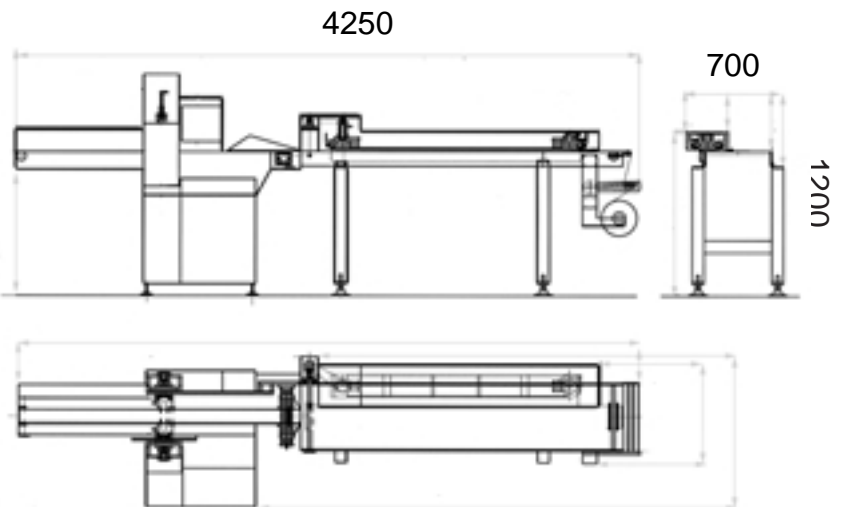

layout

### Also available:

Automatic feeding system, labellers, printers and gas flushing systems.

**imanpack**  
PACKAGING SOLUTIONS

Via lago di Bolsena, 19 36015 Schio (VI) ITALY  
tel. +39.0445-578.811 fax +39.0445-575.111  
www.imanpack.com info@imanpack.it